

15° & 30° Sloped Consoles (500 & 519 Series)



15° - Steel Base & Back
Aluminum Top



15° - Steel Base
Aluminum Back & Top



30° - Steel Base
Aluminum Back & Top

KEY FEATURES

- 18 ga. steel base for extra strength with vertical rows in sides for ventilation.
- Easy to machine - aluminum top panels are 0.064" (1.6 mm) thick aluminum.
- Sold pre-assembled with a two tone grey powder paint finish (base is dark satin gray, slope top is smooth light grey).
- Comes with four self adhesive rubber feet and required hardware.
- Replacement screws **1421J6** (Pkg. of 6, 6-32 Philips head screws).

Part Number		Slope Angle	Units	Dimensions					
Steel Back Aluminum Top	Aluminum Back & Top			A	B	C	D	E	F
500-0930		15°	inch mm	7.0 178	7.0 178	2.13 54	1.2 30	4.2 107	2.9 74
500-0940		15°	inch mm	7.6 190	7.0 178	3.78 96	2.86 73	4.2 107	2.9 74
500-0950		15°	inch mm	11.7 297	7.83 199	2.13 54	1.2 30	4.2 107	3.7 94
	515-0910	15°	inch mm	4.5 114	6.0 152	2.13 54	1.13 29	3.6 91	2.5 64
	515-0920	15°	inch mm	6.0 152	6.0 152	2.13 54	1.13 29	3.6 91	2.5 64
	515-0930	15°	inch mm	7.4 188	6.0 152	2.13 54	1.13 29	3.6 91	2.5 64
	515-0940	15°	inch mm	7.4 188	6.0 152	3.78 96	2.78 71	3.6 91	2.5 64
	515-0950	15°	inch mm	11.7 297	7.7 196	2.13 54	1.2 30	4.2 107	3.5 89
	519-0910	30°	inch mm	8.5 216	5.7 145	3.78 96	1.86 47	3.7 94	2.5 64
	519-0920	30°	inch mm	13.7 348	6.9 175	3.78 96	1.86 47	4.0 102	3.4 86

Metal

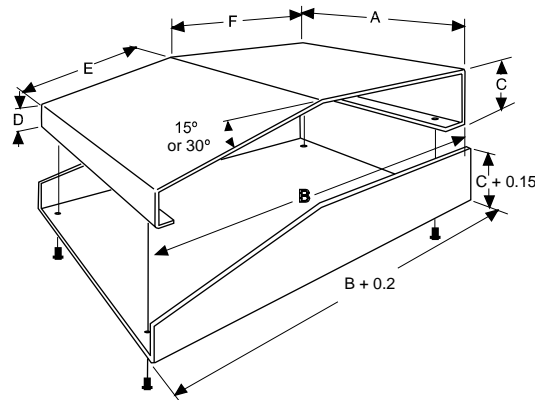

Heavy Duty Instrument (511-518 Series)

KEY FEATURES

- 18 ga. steel base and top (front & back panel will not push in from mounted buttons, controls, connectors etc.).
- Sides include two horizontal rows of ventilation.
- Choice of sloping or vertical sides by reversing case.
- Sold pre-assembled with powder paint finish. Top is dark satin grey. Bottom, front & back is smooth light grey.
- Comes with four self adhesive rubber feet and required hardware.
- Replacement screws **1421J6** (Pkg. of 6, 6-32 Philips head screws).

Part Number	Units	Dimensions			
		Width	Length (Top)	Length (Bottom)	Height
512-0900	inch	3.0	5.25	4.875	2.0
	mm	76	133	124	51
511-0900	inch	3.63	7.0	6.5	2.75
	mm	92	178	165	70
513-0900	inch	4.75	8.63	7.875	3.5
	mm	121	219	200	89



KEY FEATURES

- 18 ga. steel base and top (front & back panel will not push in from mounted buttons, controls, connectors etc.).
- Sides include one horizontal row of louvers for ventilation.
- Choice of sloping or vertical sides by reversing case.
- Includes our handle (part number **1427C1**) & holes in the top for mounting. Includes plastic plugs if handle is not used.
- Sold pre-assembled with powder paint finish. Top is dark satin grey. Bottom, front & back is smooth light grey.
- Comes with four self adhesive rubber feet and required hardware.
- Assembled with 8 machine screws into weld-nuts for repetitive assembly & disassembly.

Part Number	Units	Dimensions			
		Width	Length (Top)	Length (Bottom)	Height
518-910	inch	7.75	11.06	9.75	4.75
	mm	197	281	248	121
518-920	inch	11.75	9.63	7.75	6.25
	mm	298	245	197	159



KEY FEATURES

- Heavy duty 0.1" (2.54mm) thick aluminum base and top - for extra strength (front & back panel will not push in from mounted buttons, controls connectors, etc.). Sides include for horizontal rows of louvers for ventilation.
- Includes heavy duty 0.1" (2.54 mm) thick aluminum - raised mounting panel. Mounting surface includes 8 press nuts mounting and a 5" (127 mm) x 8.63" (219 mm) area.
- Front & back is recessed near the top with flange - to act as built in lifting handles.
- Comes with three cord grommets for front & rear holes and required assembly hardware.
- Sold pre-assembled in a light textured - dark grey powder paint finish.

Part Number	Units	Dimensions		
		Width	Length	Height
516-0010	inch	8.5	14.38	9.25
	mm	216	365	235



Metal



CANADA

Guelph, Ontario (519) 822-2960
St. Laurent, Quebec (514) 343-9010

USA

Cheektowaga, NY (716) 651-0086



EUROPE

Basingstoke, UK +44 1256 812812

AUSTRALASIA

Queenstown, SA, Australia +61 8 8240 2244